

Installation Guide

P112T

24-PORT STACKABLE ETHERNET

WORKGROUP SWITCH

Important Information

SAFETY PRECAUTIONS

CAUTION – TO REDUCE THE RISK OF ELECTRIC SHOCK AND FIRE

1. All servicing should be undertaken **ONLY** by qualified personnel. The parts inside the unit **CANNOT** be serviced or repaired by the end user. Please call your service representative for assistance.
2. Do **NOT** plug in, turn on or attempt to operate a damaged unit.
3. Ensure that the chassis ventilation slots in the unit are **NOT BLOCKED**.
4. Replace a “blown” fuse only with the same type and rating as is marked on the safety label adjacent to the power inlet housing the fuse.
5. **DO NOT** operate the unit in a location where the maximum ambient temperature exceeds 50°C.
6. Be sure to unplug the power supply cord from the wall socket **BEFORE** attempting to remove and/or check the main power fuse.

PRECAUTIONS DE SECURITÉ

AVERTISSEMENT – POUR RÉDUIRE LE RISQUE DE CHOC ÉLECTRIQUE ET D’INCENDIE

1. Tout entretien doit être fait **UNIQUEMENT** par un personnel de service qualifié. Aucun élément ne peut être réparé par un particulier.
2. **NE PAS** brancher, allumer ou essayer de faire fonctionner une unité sur laquelle un doute existe quant à son bon fonctionnement.
3. S’assurer que les ouvertures d’aération du châssis dans l’appareil **NE SONT PAS OBSTRUEES**.
4. Remplacer un fusible défaillant **UNIQUEMENT** par un modèle du même type suivant les recommandations indiquées sur l’étiquette de sécurité posée dans le logement du fusible.
5. **NE PAS** faire fonctionner l’appareil dans un endroit où la température dépasse les 50°C.
6. S’assurer de débrancher l’alimentation électrique **AVANT** toute manipulation sur le fusible principal.

SICHERHEITSVORKEHRUNG

ACHTUNG – ZUR VERHINDERUNG DES RISIKOS VON ELEKTRISCHEM SCHLAG UND FEUER

1. Die Geräte enthalten keine Bauteile, die außerhalb des Avaya Servicezentrums gewartet oder repariert werden können. Die Wartung darf **NUR** von qualifiziertem, technischem Personal durchgeführt werden.
2. **NIEMALS** ein beschädigtes Gerät einschalten, oder versuchen es zu bedienen.
3. Vergewissern Sie sich, dass die Chassis Ventilationsöffnungen des Gerätes **NICHT BLOCKIERT** sind.

4. Austauschen einer durchgebrannten Sicherung NUR mit der gleichen Sorte und Belastbarkeit wie sie auf der Sicherheitsaufschrift markiert ist. Die Aufschrift befindet sich neben der Stromzufuhr wo sich auch der Sicherungskasten befindet.
5. Bedienen Sie das Gerät NICHT an einer Stelle an der die Umgebungstemperatur 50°C übersteigt.
6. Ziehen Sie das Netzkabel raus, BEVOR Sie versuchen die Hauptsicherung zu kontrollieren oder auszutauschen.

Overview

This Installation Guide consists of three sections

- **Description:** A general description of the features of the P112T Stackable Switch.
- **Switch Installation:** Step-by-step instructions for getting the switch up and running.
- **Diagnostics:** Illustration of the front panel with LED indicators and their meanings.

Description

The P112T Stackable Switch provides wire-speed switching between 24 10BASE-T ports and can operate in either half or full duplex Ethernet. Up to four switches can be stacked, and up to 32,000 MAC addresses per stack are supported. A redundant power supply may be used for enhanced fault tolerance.

The units are linked using the P110 Exoplane connectors. These make up a multi-gigabit, non-blocking backplane. A stack of two or more switches requires a P110 NMA management agent.

The P112T Stackable Switch has a set of services which ensure zero data loss. An automatic fairness mechanism ensures that all ports gain fair access to the P110 Exoplane even at very high network utilization. Congestion management ensures no packet loss by throttling back the traffic from the sending stations should the buffers become saturated during peak load conditions.

Installation

The procedure for getting the P112T up and running depends on whether the switch is to operate standalone or as part of a stack.

First, attach the adhesive rubber legs to the base of the switch. If the switch is to be rack mounted, do not attach the legs.

Standalone Operation

Getting the P110 switch working is quick and easy:

1. Connect the power cable to the switch,
2. Connect the Ethernet cables to the front panel ports.

To ensure proper ventilation, ensure that the P110 NMA slot is closed.

The switch is now fully operational.

In order to manage the P110 switch using Avaya MSNM (or any other SNMP based management system), a P110 NMA network management agent is required. To install the P110 NMA, refer to its Installation Guide.

Stacking Operation

To make the P112T work as part of a stack (and to give SNMP management capabilities to a single P112T), a P110 NMA with the correct software version is required. See the P112T Stackable Switch Release Notes for the required version.

To check what software version you have, see the agent configuration window in View, or see the setup main menu of the P110 NMA.

1. Before adding a switch to the P110 stack, turn off the main power to the stack, by individually switching off each switch
2. Place the P110 NMA in the top switch of the stack
3. If the P110 NMA contains the latest software version, go to step 4.

If the P110 NMA does not contain the latest agent software, you should perform a software download of the latest version.

The latest software is always shipped with the P110 NMA and is available on the Avaya Support site. See the P110 NMA Release Notes document for details.

Download is performed via TFTP using a Terminal console or via the Software Update Manager. Details can be found in the P110 NMA installation Guide.

- ① Before you download the new P110 NMA software, please note that when upgrading from P110 NMA version 8.0 or below to 8.1 or higher, all port configuration parameter settings will be lost. The following parameters will be set back to the factory defaults:
 - In the P114T the **Port Speed** (10/100 Mbps) parameter will be set to **100 Mbps**.
 - The **Port Mode** (Half/Full Duplex) parameter, will be set to **Half Duplex**.
 - **Redundancy** in the P113F will be set to **OFF**.
 - The **Auto Sense (Auto-negotiation)** process, where available, will be set to **Disabled**.
 - **All ports** will lose their VLAN assignment and will be reassigned to Generic VLAN.
 - The **Administration Status** of all P110 switches will be **Enabled**. In order to avoid any possible loops, any **port** that you **disabled** using the management software must be physically disconnected before software download. Once you have downloaded the new software, set the port to disabled again and then reconnect the cable.
4. Place the P112T in the stack. The P110 NMA must be in the top switch of the stack.
- ① To ensure proper ventilation, ensure that all empty P110 NMA slots in the stack are closed.
5. Connect P110 switches using P110 Exoplane cables, as shown in Figure 1. A switch connects to its upper neighbor through two Exoplane cables, and to its lower neighbor through another two Exoplane cables.
- ① Make sure that the P110 Exoplane cables are correctly seated by gently exerting pressure on the back of the connector.

Cabling Requirements:

- For correct operation, the P110 Exoplane must be fully connected, with all units powered up. In case units are stacked, the P110 NMA **must** be installed and connected to the P110 Exoplane. Failure to observe this requirement will cause the units to block all traffic on attached stations and segments.
- When using the P114T or P114F in the stack, make sure all switches in the stack are connected using P110 Exoplane cables with white connectors and marked C/S:B (part number 108362203). Extra cables can be ordered from your local Avaya representative.

Figure 1 Rear view of a P110 switch stack, showing how the switches are linked via the P110 Exoplane cables. A P110 NMA resides in the uppermost switch.

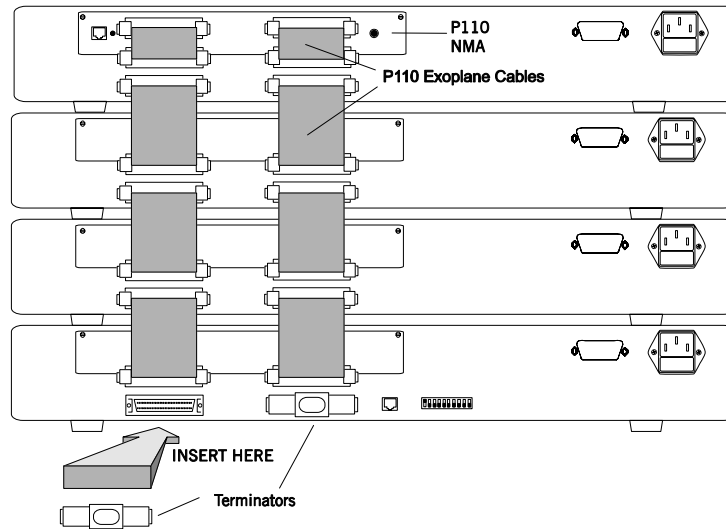

6. Two terminators are supplied with the P110 NMA. Insert the two terminators into the lowest two connectors at the bottom of the stack, as shown in Figure 1.
 7. Turn on the mains power to the stack, by individually switching on each switch.
 8. Connect the fiber-optic cables to the front panel ports.
- ① If the P110 NMA in the stack contains the correct software version (as specified in the P112T Stackable Switch Release Note) or higher, the stack is now fully operational.
 - ① When a new version of the P110 NMA software becomes available, you should perform software download to benefit from the extra capabilities provided. See the P110 NMA Installation Guide for details.

Rack Mounting

P110 switches slot into a standard 19 inch rack.

Remove the rubber legs from the base of any switch that is to be rack mounted. Place the switches in the rack, and then connect the P110 Exoplane, as follows:

1. Snap open the ends of the front panel to reveal the fixing holes.
2. Slot the switch into the rack. Insert the switches into the rack so that the switches in a logical stack lie directly on top of each other. Ensure that the P110 screw holes are aligned with the rack hole positions exactly as shown in Figure 3.
3. Stacking them in this way will allow the switches to be easily connected using the Exoplane cables.
3. Secure the switch in the rack using the screws. Use one screw on each side. Do not overtighten the screws to avoid damaging the plastic.
4. Connect the Exoplane cables, as described above, and as illustrated in Figure 1.
5. Snap closed the hinged ends of the front panel.

Figure 2 P110 rack mounting arrangement

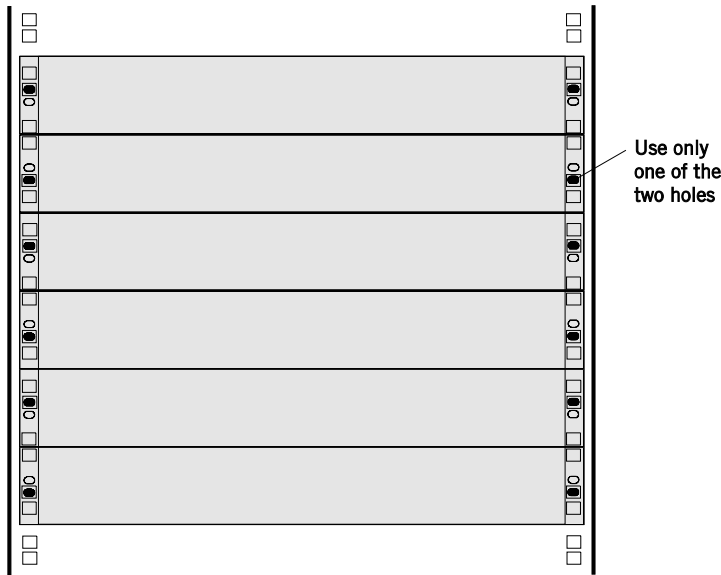

Key

- Hole in rack
- Screw hole in P110
- Screw position

Diagnostics

The following tables explain the meaning of the P112T Stackable Switch Select and Reset button and diagnostic LED indicators.

Figure 3 – The P112T Stackable Switch front panel LEDs and buttons

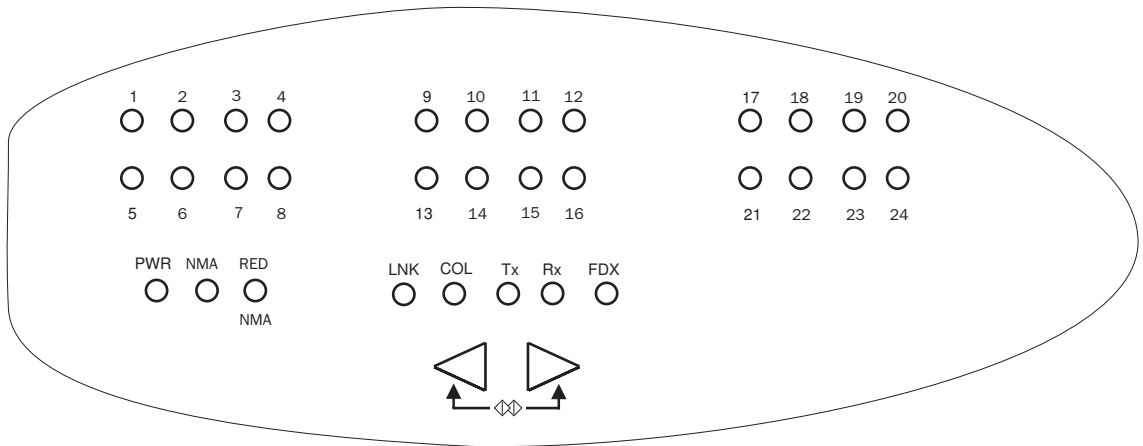

Table 1 P112T Stackable Switch Select and Reset buttons



Button	Meaning
 Select	<p>The buttons determine what function will be displayed by the 24 Port LEDs.</p> <p>The five Function LEDs show which function is currently displayed by the Port LEDs. The Port LEDs can display either Link, Collision, Full Duplex, Transmit, or Receive.</p> <p>If, for example, the Link (LNK) LED is lit then LEDs 1 to 24 will display the Link status of every port.</p> <p>Press the left or right button to toggle the Port LED display between functions</p>
 Reset	<p>Press and hold both buttons simultaneously to reset the <i>entire</i> P110 stack. Pressing Reset does not affect configuration settings.</p>

Table 2 P112T Stackable Switch front panel LED indicators

LED Indicator	Status	Meaning
PWR Power	OFF ON Blink	Mains power not connected Mains power connected Working on back-up power supply
NMA Agent	OFF ON	No agent in switch Switch contains an active agent
RED NMA	Reserved for future use.	
Port LEDs		
1 to 24	Each LED can display Link, Collision, Full Duplex, Transmit, and Receive states, depending on what has been selected using the Select buttons.	
Function LEDs		
LINK Link Status	OFF ON Blink once Blink twice	Port Disabled Port is enabled and link is OK Link Test Fail. Partition.
COL Collision	OFF ON	No Collision Collision occurred on line
FDX Half/Full Duplex	OFF ON	Half duplex – regular 10BASE-T Ethernet is connected to this port. 10BASE-T Full Duplex device is connected to this port, which means a throughput of 20 Mbps. In full duplex operation, no repeaters are allowed in the path.
TX Transmit to line	OFF ON	No activity Data transmitted
RX Receive from line	OFF ON	No activity Data Received